

Tension Brakes/Very High Heat Capacity

Kopper Kool Brakes

- **Copper disc design for high heat dissipation**
- **Accurate control**

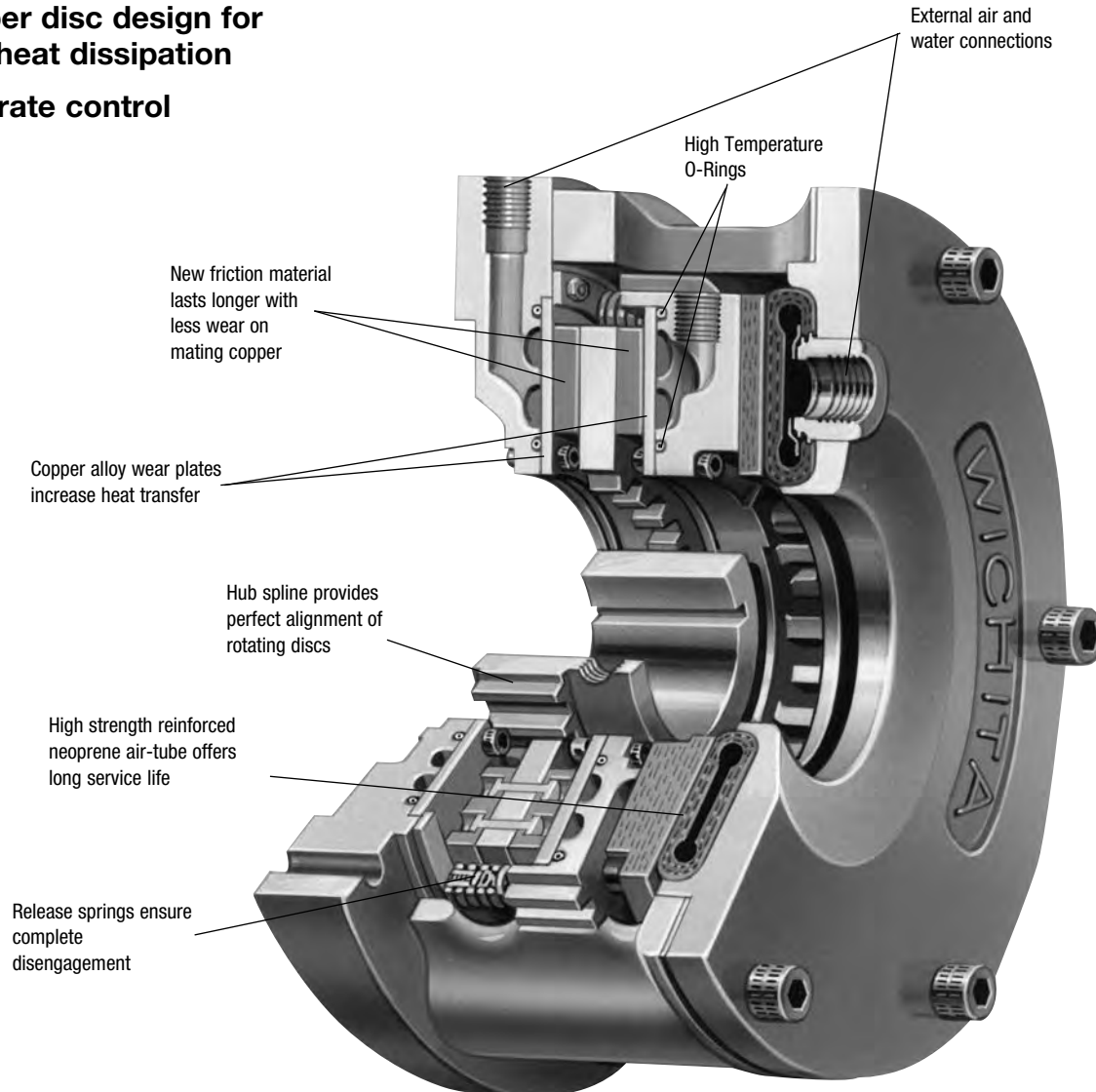

The Wichita Kopper Kool airtube disc Clutches and Brakes are liquid cooled and consist of a series of alternating discs connecting an inner drive member to an outer drive member.

Engagement is achieved by pneumatic expansion of the airtube. This air-operated clutch contains copper discs for excellent heat dissipation and provides an accurately controlled continuous slip action for constant web tensioning. Tension levels are in direct proportion to air pressure applied.

Design Features

- New friction material lasts longer with less wear on mating copper.
- Copper alloy wear plates increase heat transfer.
- Hub spline provides perfect alignment of rotating discs.
- External air & water connections.
- Release springs ensure complete disengagement.
- High strength reinforced neoprene air-tube offers long service life.
- Optional long stroke air tube available on 18" or 24" size units to increase life and standard maintenance intervals.
- High thermal capacity.

Tension Brakes/Very High Heat Capacity

Kopper Kool Brakes

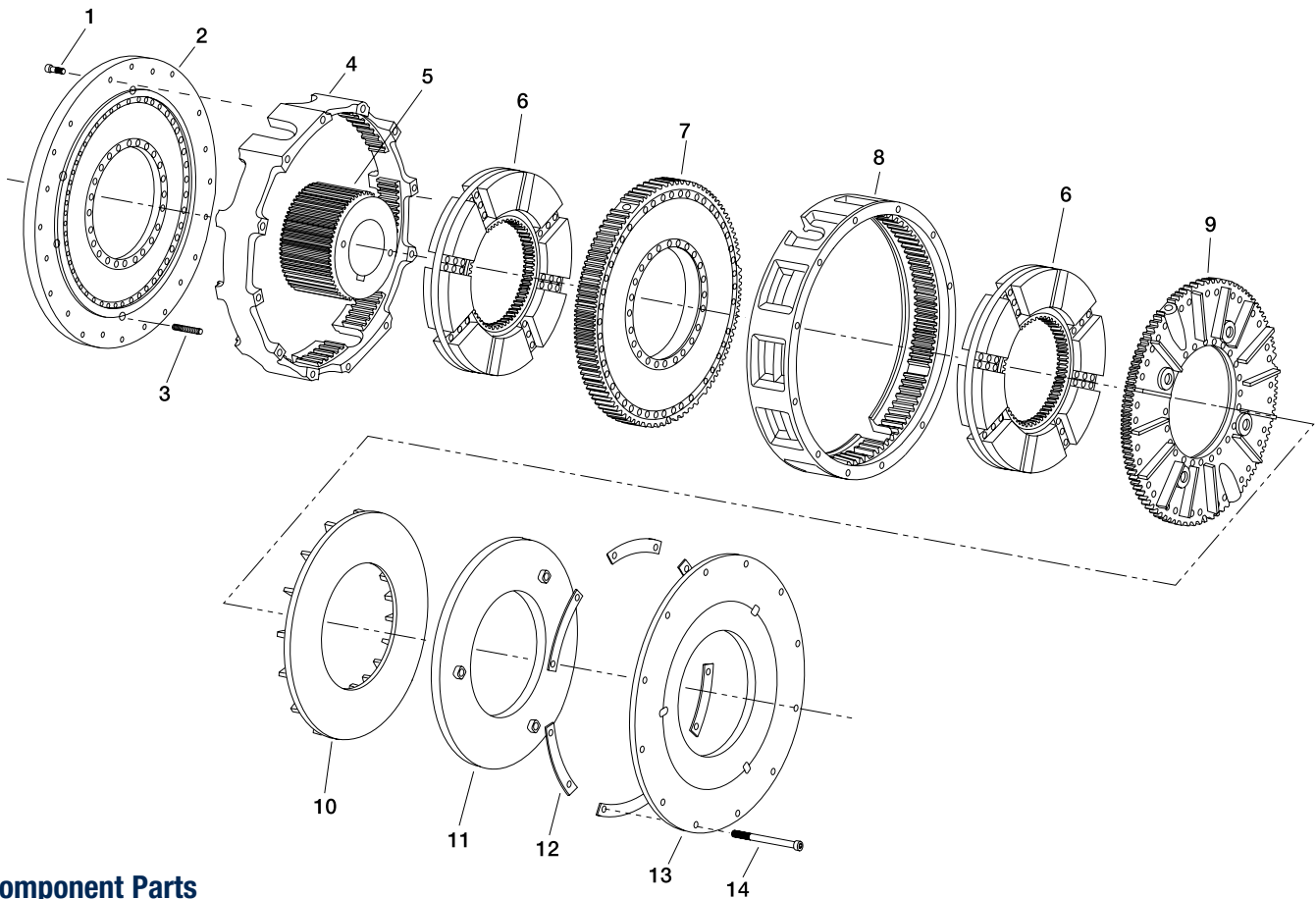

Component Parts

1. Socket Head Capscrews
2. Backplate Water Jacket Assembly
3. Release Springs
4. Ring (Backplate End)
5. Hub
6. Drive Plate Assembly
7. Center Water Jacket Assembly
8. Ring (Airtube End)
9. Floating Water Jacket Assembly
10. Pressure Plate
11. Airtube
12. Segmented Shims
13. Airtube Holding Plate
14. Socket Head Capscrews

Tension Brakes/Very High Heat Capacity

Kopper Kool Brakes

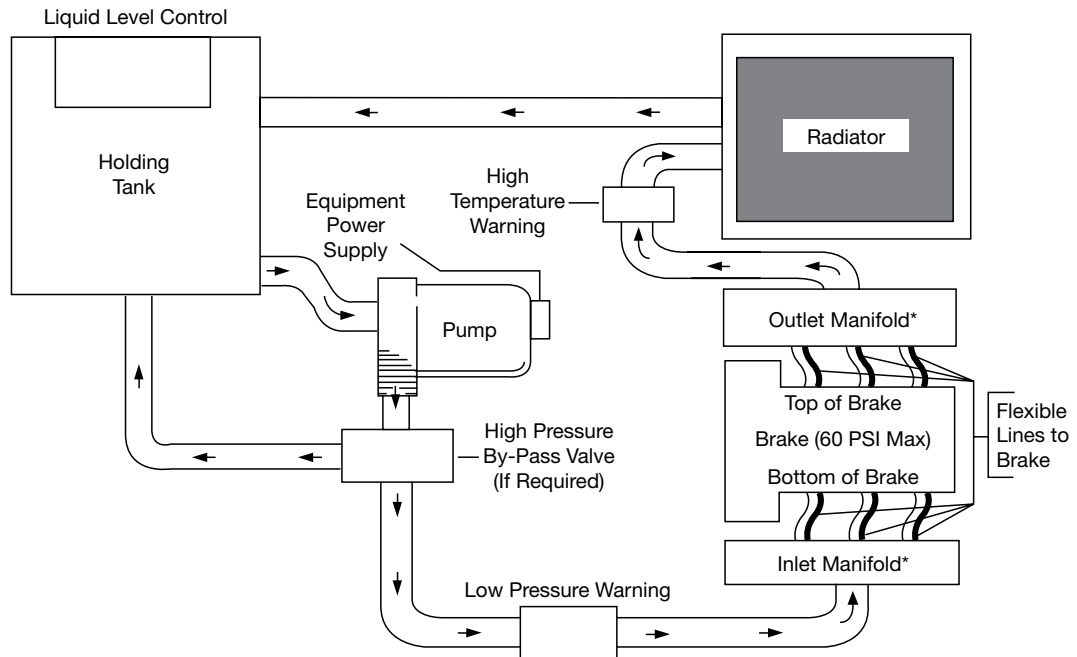

* Must be sufficient size to provide evenly distributed water flow to each water jacket

Principle of Operation

Closed Cooling System

As shown here in the closed loop system, flexible water lines should be brought into each jacket at the 6 o'clock position. When the Kopper Kool Unit is used as a clutch, air vent tubes must be installed internally at the factory to insure proper filling of the water jackets. The Kopper Kooled Clutches also require 5 PSI back pressure on the outlet side of the triple passage roto-coupling to insure complete evacuation of air from these jackets during rotation.

Referring to the closed loop cooling system, the equipment should be protected with low water pressure and high temperature warning devices. For availability information, contact factory.

Tension Brakes/Very High Heat Capacity

Kopper Kool Brakes

Design advantages

- New friction material is longer lasting with less wear on mating copper. Consistent torque response results directly with air pressure applied. Mechanically retained friction pads can be changed in field.
- Copper has a greater heat transfer capacity than any other metal other than precious metals.
- Generated teeth, in addition to providing perfect alignment of rotating members, offer maximum sensitivity of torque to pressure relationship. All factors affecting torque are fully controlled. Tangential cooling grooves insure effective mixing of cooling water for best heat conductivity. Water volume of the jackets insures high water velocity, which reduces sedimentation and chemical formation. Maximum inlet pressure is 60 PSI.
- Close grain alloy iron jackets for coolant assure maximum resistance to corrosion.
- Releasing springs insure complete disengagement.
- By using a triple roto-coupling, the brake can be used as a constant slipping clutch.
- Flexible fiberglass pressure plate assures even distribution of pressure from actuator to braking surfaces, providing maximum contact area on friction surfaces.
- All coolant and air connections are external and easily accessible. Double outlets in center water jackets for multiple plate units 24" and larger.
- Air passages through brake greatly assist in keeping brake cool.
- Actuating member is a reinforced neoprene airtube which has no resistance to movement, resulting in immediate reaction with small pressure changes. Non-corrosion neoprene is unaffected by actuating medium.

Typical Applications



Wichita Kopper Kool Brakes provide precise tension control on winch drives for mobile equipment.

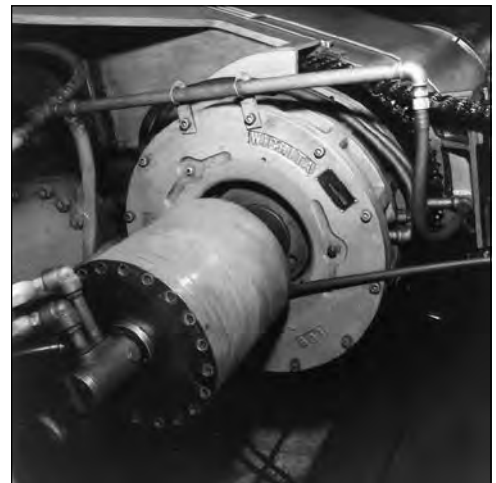

Kopper Kool Brakes dissipate high heat loads in steel uncoiler applications.

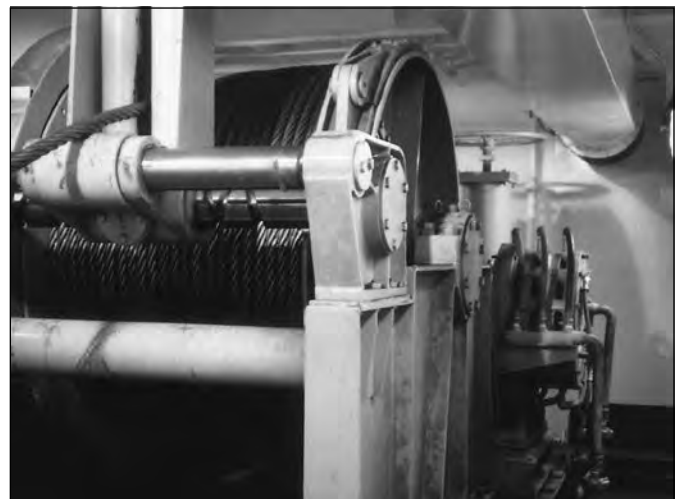

Kopper Kool brakes increase control on marine winches.



Tension Brakes/Very High Heat Capacity

Kopper Kool Brakes

Selecting for an Unwind Application

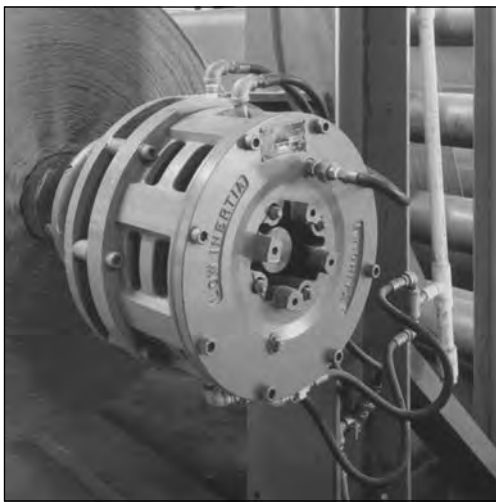

To properly select a tension brake for an unwind application the following information is needed:

Max. Roll Diameter 84 in.
 Max. Web Width 120 in.
 Max. Web Speed 1500 FPM
 Max. Tension 15 PLI
 Air Pressure Available 100 PSI
 Min. Roll Diameter 12 in.
 Min. Web Width 84 in.
 Min. Web Speed 750 FPM
 Min. Tension 10 PLI
 Shaft Size 5.00

Calculations

Using the calculations below, consult Kopper Kool Brake Specifications Chart, page 80.

The brake selected for this application is a 218 Kopper Kool, with 5.5 inch bore.

$$\begin{aligned} \text{Max. Tension} &= \text{Max. PLI} \times \text{Max. Web Width} \\ &= 15 \times 120 = 1,800 \text{ lbs.} \end{aligned}$$

$$\begin{aligned} \text{Max. Torque} &= \frac{\text{Max. Tension} \times \text{Max. Roll Dia.}}{2} \\ &= 1800 \times 84/2 = 75,600 \text{ lb.in.} \end{aligned}$$

$$\begin{aligned} \text{Max. RPM} &= \frac{\text{Max. Web Speed} \times 3.82}{\text{Min. Roll Dia.}} \\ &= 1,500 \times 3.82/12 = 478 \text{ RPM} \end{aligned}$$

$$\begin{aligned} \text{Heat HP} &= \text{Max. Tension} \times \text{Max. Web Speed} / 33,000 \\ &= \frac{1,800 \times 1,500}{33,000} = 82 \text{ Heat HP} \end{aligned}$$

$$\begin{aligned} \text{Min. Tension} &= \text{Min. PLI} \times \text{Min. Web Width} \\ &= 10 \times 84 = 840 \text{ lbs.} \end{aligned}$$

$$\begin{aligned} \text{Min. Torque} &= \frac{\text{Min. Tension} \times \text{Min. Roll Dia.}}{2} \\ &= 840 \times 12/2 = 5,040 \text{ lb.in.} \end{aligned}$$

$$\begin{aligned} \text{Min. RPM} &= \frac{\text{Min. Web Speed} \times 3.82}{\text{Max. Roll Dia.}} \\ &= 750 \times 3.82/84 = 34 \text{ RPM} \end{aligned}$$

How to select

1. Select a brake with equal to or greater thermal capacity. The ATD-214 has 150 THP @ 15 GPM. The requirement is 82 THP.
2. Check torque capacity vs. required. The ATD-214 has 42,000 lb.in. @ 100 PSI. The requirement is 75,600 lb.in. Therefore, an ATD-214 Brake will not produce enough torque for this application. An ATD-218 Brake would be the best choice.
3. Check Maximum Bore. The requirement is 5.00 inches. The ATD-218 maximum bore is 5.5 inches.
4. Check Maximum RPM. The requirement is 478 RPM. The maximum RPM for the ATD-218 is 1,300 RPM.

$$\begin{aligned} \text{Max. Air Pressure Required} &= \frac{\text{Max. Torque} \times 100 \text{ PSI}}{\text{Catalog Torque Rating}} \\ &= \frac{75,600 \times 100}{94,000} = 80 \text{ PSI} \end{aligned}$$

$$\begin{aligned} \text{Min. Air Pressure Required} &= \frac{\text{Min. Torque} \times 100 \text{ PSI}}{\text{Catalog Torque Rating}} \\ &= \frac{5,040 \times 100}{94,000} = 5 \text{ PSI} \end{aligned}$$

C

Tension Brakes/Very High Heat Capacity

Kopper Kool Brakes

Specifications

Model Size ATD-	Assembly Number	Dynamic Torque Capacity*				Heat Capacity		Max Bore Rect. Key in. (mm)	
		lb.in.		Nm		Series Water Hosing	Parallel Water Hosing		
		80 PSI	100 PSI	5.5 BAR	7 BAR	HP/kW	HP/kW		
KKB 106	7-306-110-200-0	2,720	3,400	307	384	10 / 7.5	15 / 11	1.75	(44)
KKB 206	7-306-210-200-0	5,440	6,800	614	768	20 / 15	30 / 22		
KKB 108	7-308-110-100-0	4,320	5,400	479	610	21 / 16	32 / 24		
KKB 208	7-308-210-100-0	8,640	10,800	959	1,220	42 / 31	64 / 48	2.25	(57)
KKB 308	7-308-310-101-0	12,960	16,200	1,438	1,830	63 / 47	96 / 72		
KKB 111	7-311-110-106-0	9,600	12,000	1,065	1,356	35 / 26	53 / 40		
KKB 211	7-311-210-107-0	19,200	24,000	2,131	2,712	70 / 52	105 / 78	3.00	(76)
KKB 311	7-311-310-100-0	28,800	36,000	3,196	4,067	105 / 78	158 / 118		
KKB 114	7-314-110-115-0	16,800	21,000	1,864	2,373	50 / 37	75 / 56		
KKB 214	7-314-210-111-0	33,600	42,000	3,728	4,745	100 / 75	150 / 112	4.38	(111)
KKB 314	7-314-310-103-0	50,400	63,000	5,593	7,118	150 / 112	225 / 168		
KKB 116	7-316-110-107-0	25,600	32,000	2,841	3,615	65 / 48	98 / 73	4.75	(121)
KKB 216	7-316-210-108-0	51,200	64,000	5,681	7,231	130 / 97	195 / 145		
KKB 118	7-318-110-100-0	37,600	47,000	4,172	5,310	80 / 60	120 / 89		
KKB 218	7-318-210-100-0	75,200	94,000	8,344	10,620	160 / 119	240 / 179	5.50	(140)
KKB 318	7-318-310-101-0	112,800	141,000	12,517	15,930	240 / 179	360 / 268		
KKB 119	7-319-110-104-0	52,000	65,000	5,770	7,344	—	160 / 119	5.50	(140)
KKB 219	7-319-210-111-0	104,000	130,000	11,540	14,688	—	320 / 239		
KKB 121	7-321-110-100-0	49,600	62,000	5,504	7,005	100 / 75	150 / 112		
KKB 221	7-321-210-102-0	99,200	124,000	11,008	14,010	200 / 149	300 / 224	6.50	(165)
KKB 321	7-321-310-100-0	148,800	186,000	16,511	21,015	300 / 224	450 / 336		
KKB 124H	7-325-110-100-0	100,800	126,000	11,185	14,236	190 / 142	285 / 213		
KKB 224H	7-325-210-101-0	201,600	252,000	22,370	28,471	380 / 283	570 / 425	7.63	(194)
KKB 324H	7-325-310-101-0	302,400	378,000	33,556	42,707	570 / 425	855 / 638		
KKB 125	7-326-100-100-0 ¹	122,920	153,650	13,880	17,360	—	350/261		
KKB 225	7-326-200-100-0 ¹	245,840	307,300	27,760	34,719	—	700 / 522	8.13	(207)
KKB 325	7-326-300-101-0 ¹	368,760	460,950	41,640	52,079	—	1050/783		
KKB 127	7-327-110-100-0	120,000	150,000	13,316	16,947	175 / 130	263 / 196	8.00	(203)
KKB 227	7-327-210-100-0	240,000	300,000	26,631	33,894	350 / 261	233 / 174		
KKB 130	7-330-110-300-0	160,000	200,000	17,754	22,596	230 / 172	345 / 257		
KKB 230	7-330-210-301-0	320,000	400,000	35,508	45,193	460 / 343	690 / 515	9.00	(229)
KKB 330	7-330-310-300-0	480,000	600,000	53,263	67,789	690 / 515	1,035 / 772		
KKB 136H	7-337-110-300-0	320,000	400,000	36,154	45,193	500 / 373	750 / 559		
KKB 236H	7-337-210-300-0	640,000	800,000	72,308	90,385	1,000 / 746	1,500 / 1,119	9.00	(229)
KKB 336H	7-337-310-300-0	960,000	1,200,000	108,462	135,578	1,500 / 1,119	2,250 / 1,678		
KKB 436H	7-337-410-102-0 ²	1,250,000	1,600,000	141,227	180,771	2,000 / 1,491	3,000 / 2,237		

* Static torque will vary with temperature. Maximum air pressure is 100 PSI / 7 BAR. Minimum recommended air pressure is 3 PSI.

Note: Maximum water jacket inlet pressure is 60 PSI.

Brakes with as great as 50% higher torque capacity is available upon request.

¹ Current design is with enhanced linings. A unit with regular linings is available upon request.

² Current design is with the Marine Corrosion package. A Non-Marine unit is available upon request.

³ Current design is for intermittent duty applications. Such as, anchor, mooring, take-up and traction type winch applications.

⁴ For information purposes, not for new applications

Tension Brakes/Very High Heat Capacity

Kopper Kool Brakes Specifications

Model Size ATD-	Recom- mended Clearance in.(mm)	Max. Speed RPM	Parallel Water Flow % Ethylene Glycol GPM (LPM)			Total Brake Wt.		Hub & Drive Plate Wt.				
			0%	30%	50%	lb.	(kg)	lb.	(kg)	WR ² / J=mr ²	lb.ft. ²	(kg m ²)
KKB 106	1/16-3/32 (1.5-2)	3,800	1.5 (6)	2.0 (7.4)	2.3 (8.5)	45	(20.4)	5.5	(2.5)	0.14	(0.01)	
KKB 206			3 (11)	3.9 (14.8)	4.5 (17)	71	(32.2)	11.7	(5.3)	0.28	(0.01)	
KKB 108	1/16-3/32 (1.5-2)		3.2 (12)	4.1 (1.6)	5 (19)	68	(30.8)	11	(5.0)	0.6	(0.03)	
KKB 208	3/32-5/32 (2-4)	2,860	6.4 (24)	8.2 (32)	10 (38)	116	(52.6)	25	(11.1)	1.3	(0.05)	
KKB 308	1/8-3/16 (3-5)		9.6 (36)	12.3 (48)	15 (57)	164	(74.4)	38	(17.2)	2.0	(0.08)	
KKB 111	1/16-3/32 (1.5-2)		5.3 (20)	6.9 (26)	8 (30)	146	(66.2)	24	(10.9)	2	(0.08)	
KKB 211	3/32-5/32 (2-4)	2,100	10.5 (40)	13.7 (52)	15.8 (60)	230	(104.3)	54	(24.5)	4	(0.17)	
KKB 311	1/8-3/16 (3-5)		15.8 (60)	20.5 (78)	20.5 (78)	314	(142.4)	84	(38.1)	6.0	(0.25)	
KKB 114	1/16-3/32 (1.5-2)		7.5 (28)	9.8 (37)	12 (45)	221	(100.2)	40	(18)	5	(0.21)	
KKB 214	3/32-5/32 (2-4)	1,600	15 (57)	20 (74)	24 (90)	345	(156.5)	80	(36)	11	(0.44)	
KKB 314	1/8-3/16 (3-5)		22.5 (84)	29 (111)	36 (135)	470	(213.2)	120	(54)	16	(0.67)	
KKB 116	1/16-3/32 (1.5-2)	1,400	9.8 (37)	12.7 (48)	15 (56)	298	(135)	75	(34)	12	(0.51)	
KKB 216	3/32-5/32 (2-4)		19.5 (74)	25.4 (96)	29 (111)	650	(295)	143	(65)	25	(1.07)	
KKB 118	1/16-1/8 (1.5-2)		12 (45)	16 (60)	19 (72)	415	(188)	88	(39.9)	18	(0.76)	
KKB 218	3/32-5/32 (2-4)	1,300	24 (90)	32 (120)	38 (144)	565	(256)	176	(79.8)	36	(1.52)	
KKB 318	1/8-3/16 (3-5)		36 (135)	48 (180)	57 (216)	715	(324)	264	(119.7)	54	(2.28)	
KKB 119	3/32-5/32 (2-4)	1,200	16 (61)	21 (79)	24 (91)	337	(153)	84	(38)	12.5	(0.53)	
KKB 219	3/32-5/32 (2-4)		32 (121)	42 (158)	48 (182)	464	(210)	144	(65)	21.6	(0.91)	
KKB 121	3/32-5/32 (2-4)		15 (57)	20 (74)	24 (90)	600	(272)	138	(63)	34	(1.43)	
KKB 221	1/8-3/16 (3-5)	1,100	30 (114)	39 (148)	45 (170)	870	(395)	226	(103)	64	(2.70)	
KKB 321	5/32-7/32 (4-6)		45 (170)	59 (221)	68 (255)	1,075	(488)	301	(137)	97	(4.09)	
KKB 124H	3/32-5/32 (2-4)		29 (106)	38 (144)	45 (170)	935	(424)	240	(109)	110	(4.64)	
KKB 224H	1/8-3/16 (3-5)	960	58 (212)	76 (288)	90 (340)	1,500	(680)	410	(186)	210	(8.85)	
KKB 324H	5/32-7/32 (4-6)		87 (318)	114 (432)	135 (510)	2,065	(937)	580	(263)	310	(13.07)	
KKB 125	3/32-5/32 (2-4)		35 (132)	45 (170)	54 (204)	886	(402)	—	—	—	—	
KKB 225	1/8-3/16 (3-5)	935	70 (264)	90 (340)	108 (408)	1,421	(645)	—	—	—	—	
KKB 325	5/32-7/32 (4-6)		105 (396)	135 (510)	162 (611)	1,956	(887)	—	—	—	—	
KKB 127	3/32-5/32 (2-4)	850	27 (102)	35 (133)	41 (153)	981	(445)	227	(103)	92	(3.87)	
KKB 227	1/8-3/16 (3-5)		54 (204)	70 (266)	81 (307)	1,320	(599)	426	(193)	179	(7.55)	
KKB 130	3/32-5/32 (2-4)		35 (132)	45 (170)	54 (204)	1,134	(514)	263	(119)	139	(5.86)	
KKB 230	1/8-3/16 (3-5)	760	70 (264)	90 (340)	108 (408)	1,850	(839)	530	(240)	275	(11.59)	
KKB 330	5/32-7/32 (4-6)		105 (396)	135 (510)	162 (612)	2,565	(1,163)	795	(361)	410	(17.28)	
KKB 136H	3/32-5/32 (2-4)		75 (284)	98 (369)	120 (454)	2,550	(1,157)	535	(243)	410	(17.28)	
KKB 236H	1/8-3/16 (3-5)	640	150 (568)	195 (738)	240 (908)	4,111	(1,865)	925	(420)	790	(33.31)	
KKB 336H	5/32-7/32 (4-6)		225 (852)	294 (1,107)	360 (1,362)	5,595	(2,538)	1,685	(764)	1,621	(68.3)	
KKB 436H	3/16-1/4 (5-7)		300 (1,136)	390 (1,476)	450 (1,703)	6,772	(3,072)	2,198	(997)	2,079	(87.6)	

C

Tension Brakes/Very High Heat Capacity

Kopper Kool Brakes

Specifications

Model Size	Pressure Drop Parallel Flow w/ % Ethylene Glycol PSI / (BAR)			Pressure Drop Series Flow w/ % Ethylene Glycol PSI / (BAR)			Maximum Lining Wear		Water Volume in. ³ / (dm ³)
	0%	30%	50%	0%	30%	50%	in./(cm)	in. ³ /(dm ³)	
ATD-									
KKB 108				4 (0.14)	9 (0.62)	9 (0.62)			8 (0.13)
KKB 208	0.9 (0.06)	1.6 (0.11)	2.3 (0.16)	11(0.76)	25 (1.72)	32 (2.21)	0.4 (1.0)	10 (0.2)	16 (0.26)
KKB 308				15(1.03)	34 (2.34)	41 (2.83)			24 (0.4)
KKB 114				4 (0.14)	8 (0.55)	12 (0.83)			20 (0.33)
KKB 214	1.2 (0.08)	1.6 (0.11)	1.8 (0.12)	24(1.66)	40 (2.76)	52 (3.59)	0.5 (1.3)	60 (1.0)	40 (0.65)
KKB 314				28 (1.93)	48 (3.31)	—			60 (1)
KKB 118				7 (0.48)	13 (0.9)	20 (1.38)			48 (0.8)
KKB 218	1.7 (0.12)	2.4 (0.17)	2.8 (0.19)	52 (3.59)	—	—	0.6 (1.5)	75 (1.2)	96 (1.5)
KKB 318				—	—	—			144 (2.35)
KKB 124H				7 (0.48)	11 (0.76)	14 (0.97)			110 (1.8)
KKB 224H	1.9 (0.13)	2.4 (0.17)	3.1 (0.21)	23 (1.59)	35 (2.41)	48 (3.31)	0.8 (2.0)	200 (3.3)	220 (3.6)
KKB 324H				30 (2.07)	46 (3.17)	—			330 (1.8)
KKB 130				9 (0.62)	14 (0.97)	21 (1.45)			190 (3.1)
KKB 230	2.1 (0.14)	2.4 (0.17)	3.1 (0.21)	31 (2.14)	48 (3.31)	—	0.8 (2.0)	240(3.9)	380 (6.2)
KKB 330				40 (2.76)	—	—			570 (9.3)
KKB 136H				14 (0.97)	24 (1.66)	—			285 (4.7)
KKB 236H	4.0 (0.28)	5.3 (0.37)	7.2 (0.50)	60 (4.14)	—	—	0.8 (2.0)	500 (8.2)	570 (9.3)
KKB 336H				—	—	—			855 (14)

PSI Pressure Curves

The cooling water requirements are listed in the specification table. The pressure drop across the brakes is given for both parallel and series flow. This table also indicates the increased flow requirement when using a mixture of ethylene glycol as an antifreeze or for corrosion protection.

The normal water requirement for Kopper Kool brakes and clutches is one gallon of water for each 10 horsepower or one liter of water for each 2 kilowatts being dissipated. This amount of flow will give a temperature rise through the brake of 50° F (28° C). The outlet water temperature should not exceed 170° F (77° C).

The curves shown in Figures 1 and 3 indicate the pressure through the listed units for both parallel and series flow. Also shown in Figure 2 is the flow through the optional triple passage roto-couplings for Kopper Kool clutches. The data in Figures 1, 2, and 3 will aid in estimating pressure drops for different flow requirements.

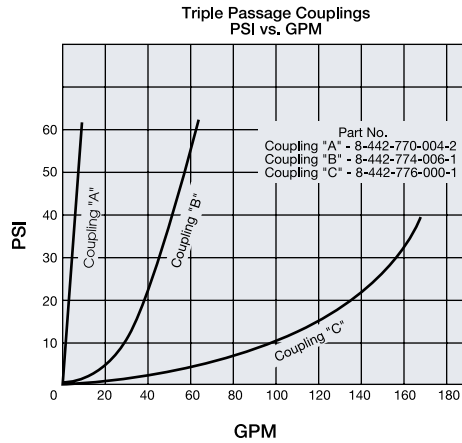

Figure 2

From Figure 2 for 20 GPM PSI drop is 5. The pressure drop would be 6.2 PSI across the inlet and outlet of coupling "B" for this application.

Horsepower ratings as shown are for continuous slip. The ratings can be increased for intermittent service. Please consult the factory for such applications.

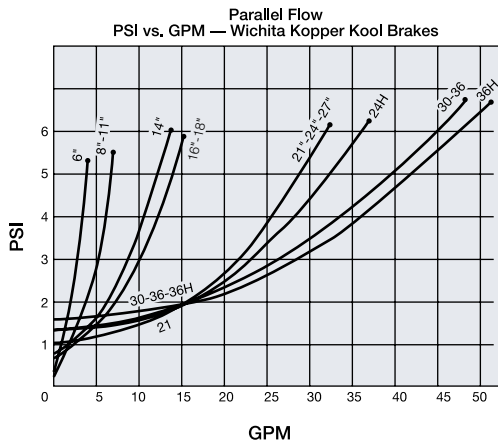

Figure 1

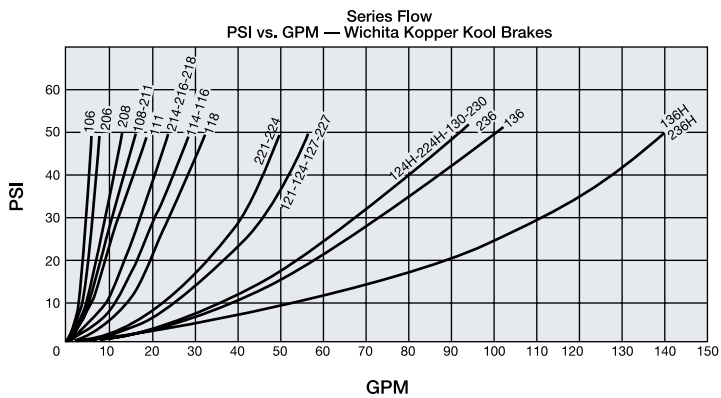

Figure 3

An example of the use of these flow tables is: An ATD-224H clutch is selected for 200 horsepower @ 190 RPM.

The torque requirement is 66,316 lb.in.

Water flow required = 20 GPM
(4 inlets - 4 outlets @ 5 GPM ea.)

From Figure 1 for 20 GPM
(24H Curve at 5 GPM) PSI drop is 1.2.

Tension Brakes/High Heat Capacity

Kopper Kool Brakes

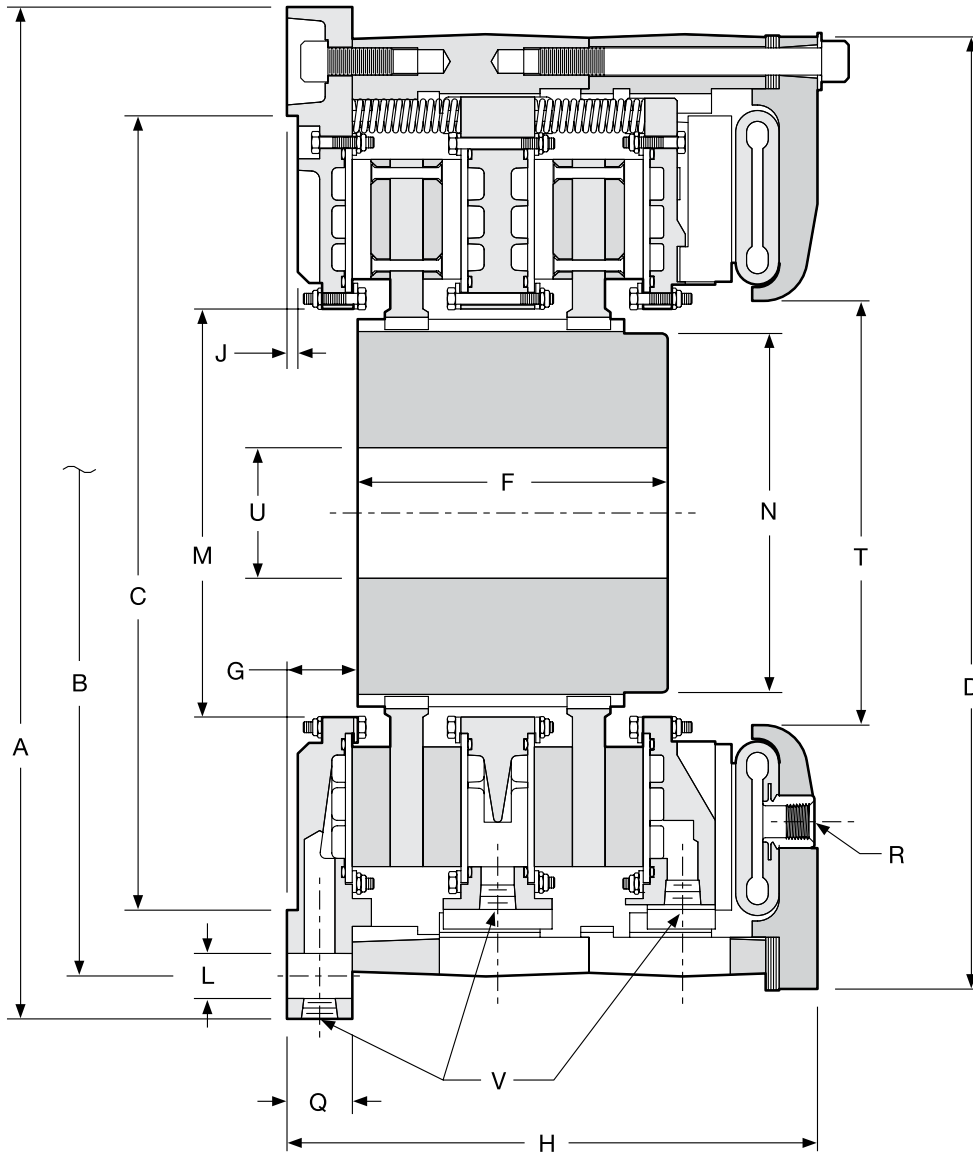

For mounting hole pattern, see following pages.
For sizes 19 and 25 see page 88.

Tension Brakes/High Heat Capacity

Kopper Kool Brakes

Dimensions: inches (mm)

Model Size ATD-	A Pilot	B Hole Circle	C Pilot	D	F	G	H	J
KKB 106	8.751 / 8.753	8.000	7.377 / 7.379	8.81	2.00 (50.8)		5.25 (133.4)	
KKB 206	(222.28 / 222.33)	(203.20)	(187.38 / 187.43)	(223.8)	4.63 (117.6)	.75(19.1)	7.63 (193.8)	0.13 (3.3)
KKB 108	12.125 / 12.128	11.125	8.375 / 8.378	11.75	2.00 (50.8)		5.68 (144.3)	
KKB 208	(307.98 / 308.05)	(282.58)	(212.73 / 212.80)	(288.5)	4.25 (108)	1.13(28.7)	8.43 (214.1)	0.25 (6.4)
KKB 308					7.00 (177.8)		11.12 (282.4)	
KKB 111	15.997 / 16.000	14.75	11.375 / 11.378	14.75	2.88 (73.2)		6.32 (160.5)	
KKB 211	(406.32 / 406.40)	(374.65)	(288.93 / 289.00)	(374.7)	6.13 (155.7)	.75 (19.1)	9.56 (242.8)	0.25(6.4)
KKB 311					9.12 (231.6)		12.81 (325.4)	
KKB 114	18.747 / 18.750	17.500	14.375 / 14.378	17.50	3.25 (82.6)	1.06(26.9)	7.00 (177.8)	
KKB 214	(476.17 / 476.25)	(444.50)	(365.13 / 365.20)	(444.5)	5.88 (149.4)	1.69 (42.9)	10.57 (268.5)	0.25(6.4)
KKB 314					9.13 (231.9)	1.69 (42.9)	14.13 (358.9)	
KKB 116	21.245 / 21.248	20.000	16.250 / 16.253	20.00	4.00 (101.6)	1.25(31.8)	7.56 (192.0)	
KKB 216	(539.62 / 539.70)	(508.00)	(412.75 / 412.83)	(508.0)	7.00 (177.8)		11.50 (292.1)	0.25(6.4)
KKB 118	23.247 / 23.250	22.000	18.250 / 18.253	21.88	3.63 (92.1.2)	1.06 (26.9)	8.00 (203.2)	
KKB 218	(590.47 / 590.55)	(558.80)	(463.55 / 463.63)	(555.8)	7.13 (181.1)	1.63 (41.4)	12.19 (309.6)	0.25(6.4)
KKB 318					10.75 (273.1)	1.63 (41.4)	16.38 (416.1)	
KKB 121	26.977 / 27.000	25.500	21.375 / 21.378	24.88	5.50 (139.7)	1.25 (31.8)	8.38 (212.9)	
KKB 221	(685.22 / 685.80)	(647.70)	(542.93 / 543.00)	(632.0)	7.94 (201.7)	1.50 (38.1)	15.81 (401.6)	0.25(6.4)
KKB 321					12.44 (316.0)	1.25 (31.8)	17.19 (436.6)	
KKB 124H	29.997 / 30.000	28.750	24.375 / 24.378	31.00	5.00 (127.0)		9.79 (248.7)	
KKB 224H	(761.9 / 762.0)	(730.25)	(619.13 / 619.20)	(787.4)	8.63 (219.2)	1.38 (35.1)	14.68 (372.9)	0.25 (6.4)
KKB 324H					13.63 (346.2)		19.56 (496.8)	

Dimensions: inches (mm)

Model Size ATD-	L		M	N	Q	R		T	U		V ¹ - Inlets	
	No. -	Size				No. -	Size		Min.	Max.	No. -	Size
KKB 106			2.94	2.43	0.38			2.00	0.60	1.75		2 - 1/4 NPT
KKB 206	4 -	0.34 (8.6)	(74.7)	(61.7)	(9.7)	2 -	1/2 NPT	(50.8)	(15.2)	(44.5)		3 - 1/4 NPT
KKB 108												2 - 3/8 NPT
KKB 208	4 -	17/32 (13.5)	4.38	3.50	1.38	2 -	1/2 NPT	3.75	1.00	2.25		3 - 3/8 NPT
KKB 308			(111.3)	(88.9)	(35.1)			(95.3)	(25.4)	(57.2)		4 - 3/8 NPT
KKB 111												2 - 1/2 NPT
KKB 211	4 -	21/32 (16.7)	5.38	4.63	1.13	2 -	1/2 NPT	5.25	1.00	3.00		3 - 1/2 NPT
KKB 311			(136.7)	(117.6)	(28.7)			(133.4)	(25.4)	(76.2)		4 - 1/2 NPT
KKB 114												2 - 1/2 NPT
KKB 214	6 -	21/32 (16.7)	7.38	6.50	1.50	2 -	1/2 NPT	7.00	1.38	4.38		3 - 1/2 NPT
KKB 314			(187.5)	(165.1)	(38.1)			(177.8)	(35.1)	(111.3)		4 - 1/2 NPT
KKB 116	10 -	21/32 (16.7)	8.62	7.50	1.50	2 -	1/2 NPT	8.38	1.38	4.75		2 - 1/2 NPT
KKB 216			(218.9)	(190.5)	(38.1)			(212.9)	(35.1)	(120.7)		3 - 1/2 NPT
KKB 118												2 - 1/2 NPT
KKB 218	10 -	21/32 (16.7)	9.38	8.25	1.50	3 -	1/2 NPT	9.75	2.00	5.50		3 - 1/2 NPT
KKB 318			(238.3)	(209.6)	(38.1)			(247.7)	(50.8)	(139.7)		4 - 1/2 NPT
KKB 121												2 - 3/4 NPT
KKB 221	10 -	21/32 (16.7)	11.38	10.50	1.75	3 -	1/2 NPT	11.38	2.00	6.50		3 - 3/4 NPT
KKB 321			(289.1)	(266.7)	(44.5)			(289.1)	(50.8)	(165.1)		4 - 3/4 NPT
KKB 124H												2 - 1 NPT
KKB 224H	10 -	21/32 (16.7)	12.69	11.50	.94	3 -	1/2 NPT	15.12	2.00	7.63		4 - 1 NPT
KKB 324H			(322.3)	(292.1)	(23.9)			(384.0)	(50.8)	(193.8)		6 - 1 NPT

NOTE: For mounting, use socket head capscrews conforming to the ASTM-574-97a.

¹ Number of inlets and outlets are equivalent.

(Consult factory for drawing before final layout.)

Tension Brakes/High Heat Capacity

Kopper Kool Brakes

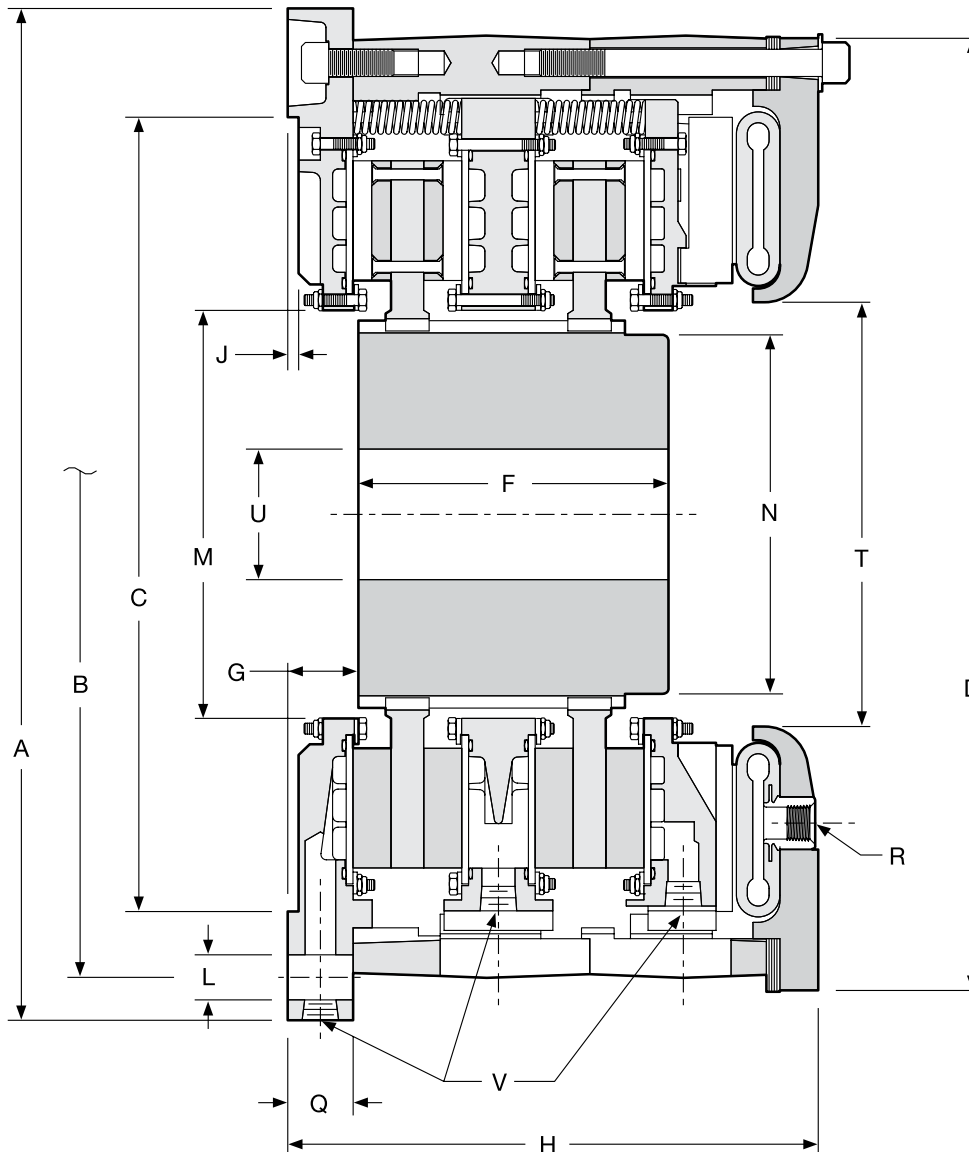

For mounting hole pattern, see following pages.
For sizes 19 and 25 see page 88.

Tension Brakes/High Heat Capacity

Kopper Kool Brakes

Dimensions: inches (mm)

Model Size ATD-	A Pilot	B Hole Circle	C Pilot	D	F	G	H	J
KKB 127	32.747 / 32.750 (831.77 / 831.85)	31.500 (800.10)	27.375 / 27.378 (695.33 / 695.40)	15.13 (384.3)	5.00 (127)	1.38 (35.1)	9.00 (228.6)	0.25 (6.4)
KKB 227					8.63 (219.2)		13.75 (349.3)	
KKB 130					4.63 (117.6)		9.44 (239.8)	
KKB 230	36.997 / 37.000 (939.72 / 939.80)	35.500 (901.70)	30.375 / 30.378 (771.53 / 771.60)	34.75 (882.7)	9.25 (235)	1.38 (35.1)	14.25 (362)	0.25 (6.4)
KKB 330					13.88 (352.6)		19.00 (482.6)	
KKB 136H					5.63 (143)	1.13 (28.7)	12.63 (320.8)	
KKB 236H	43.497 / 43.500 (1,104.82 / 1,104.90)	42.000 (1066.80)	36.375 / 36.378 (923.93 / 924.00)	44.50 (1,130.3)	11.00 (279.4)	1.43 (36.3)	19.26 (489.2)	0.25 (6.4)
KKB 336H					16.63 (422.4)	1.43 (36.3)	25.76 (654.3)	
KKB 436H	44.50 (1,130.3)	42.500 (1,079.50)	36.375 / 36.378 (923.93 / 924.00)	44.50 (1,130.3)	24.75 (628.7)	1.43 (36.3)	32.26 (819.4)	0.25 (6.4)

Dimensions: inches (mm)

Model Size ATD-	L		M	N	Q	R		T	U		V ¹ - Inlets	
	No. -	Size				No. -	Size		Min.	Max.	No. -	Size
KKB 127	14 -	21/32 (16.7)	14.13 (358.9)	12.50 (317.5)	1.75 (44.5)	3 -	1/2 NPT	15.13 (358.9)	2.50 (63.5)	8.00 (203.2)	2 -	3/4 NPT
KKB 227											3 -	3/4 NPT
KKB 130											2 -	1 NPT
KKB 230	16 -	25/32 (19.8)	15.75 (400.1)	14.25 (362)	2.00 (50.8)	4 -	1/2 NPT	17.38 (441.5)	2.50 (63.5)	9.00 (228.6)	4 -	1 NPT
KKB 330											6 -	1 NPT
KKB 136H											2 -	1.25 NPT
KKB 236H	16 -	13/16 (20.6)	16.50 (419.1)	14.00 (355.6)	1.19 (30.2)	4 -	1/2 NPT	17.38 (441.5)	6.00 (152.4)	9.00 (228.6)	4 -	1.25 NPT
KKB 336H											6 -	1.25 NPT
KKB 436H	16 -	1.06 (26.9)	16.50 (419.1)	14.00 (355.6)	1.25 (31.8)	4 -	1/2 NPT	17.38 (441.5)	6.00 (152.4)	9.00 (228.6)	8 -	1.25 NPT

NOTE: For mounting, use socket head capscrews conforming to the ASTM-574-97a.

¹ Number of inlets and outlets are equivalent.

(Consult factory for drawing before final layout.)

² For information purposes. Not for new applications.

Tension Brakes/High Heat Capacity

Kopper Kool Brakes

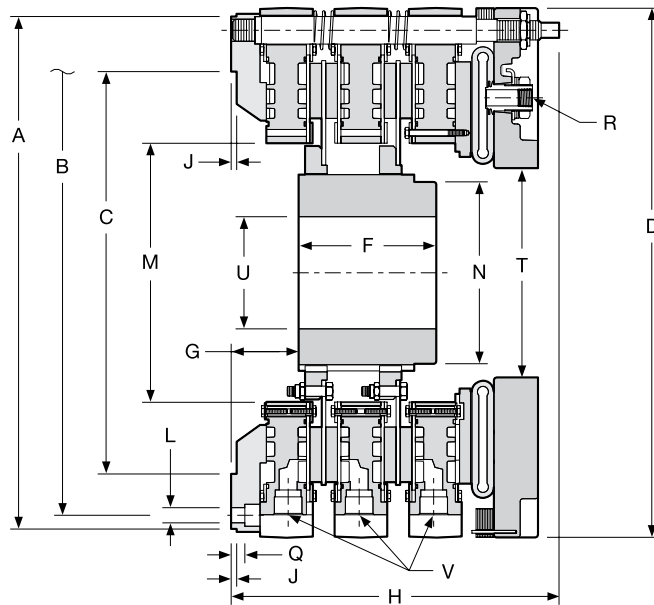

Size 19

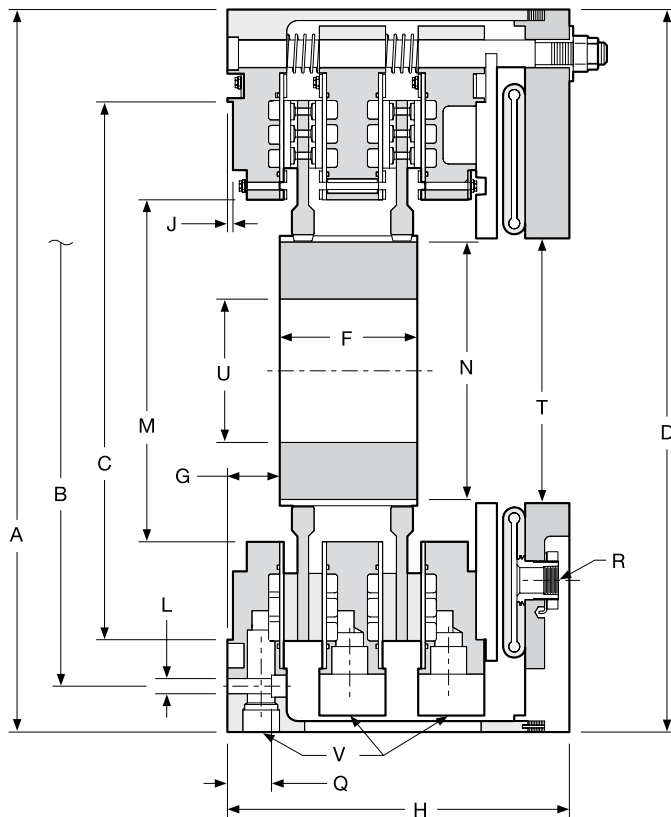

Size 25

For mounting hole pattern, see following pages.

Tension Brakes/High Heat Capacity

Kopper Kool Brakes

Dimensions: inches (mm)

Model Size ATD-	A Pilot	B Hole Circle	C Pilot	D	F	G	H	J
KKB 119	23.247 / 23.250 (590.47 / 590.55)	22.000 (558.80)	18.253 / 18.256 (463.63 / 463.70)	24.00 (609.6)	3.63 (92.2)	3.00 (76.2)	11.50 (292.1)	0.25 (6.4) ^{KKB}
KKB 219					6.25 (158.8)	3.06 (77.7)	14.87 (377.7)	
KKB 125					5.00 (127)		11.00 (279)	
KKB 225	32.75 ² (831.9)	28.750 (730.25)	24.375 / 24.378 (619.13 / 619.20)	32.75 (831.9)	6.25 (158.8)	2.36 (59.9)	15.50 (393.7)	0.25 (6.4)
KKB 325					13.62 (346)		19.87 (505)	

Dimensions: inches (mm)

Model Size ATD-	L		M	N	Q	R		T	U		V ¹ - Inlets
	No. -	Size				No. -	Size		Min.	Max.	No. - Size
KKB 119			11.75 (298.5)	8.25 (209.6)	0.62 (15.7)	4 -	1/2 NPT	9.50 (241.3)	2.75 (70)	5.50 (140)	2 - 1.31-12UN SAE "O" RING
KKB 219											4 - 1.31-12UN SAE "O" RING
KKB 125											2 - 1.25 NPT
KKB 225	12 -	21/32 (16.7)	15.50 (393.7)	11.67 (296.4)	2.00 (50.8)	4 -	1 NPT	12.00 (304.8)	4.00 (102)	8.13 (207)	4 - 1.25 NPT
KKB 325											6 - 1.25 NPT

NOTE: For mounting, use socket head capscrews conforming to the ASTM-574-97a.

¹ Number of inlets and outlets are equivalent.

² Not a pilot but a nominal dimension only.

(Consult factory for drawing before final layout.)

Tension Brakes/High Heat Capacity

Kopper Kool Brakes

Mounting Hole Pattern

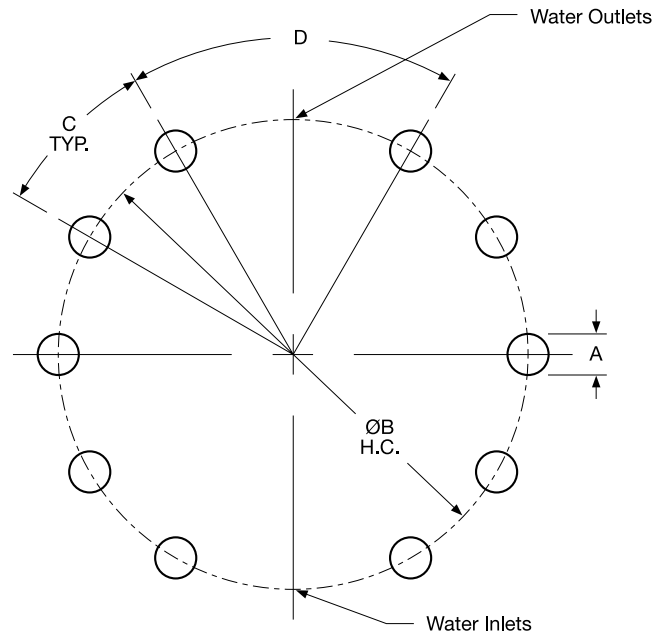

KKB Brakes

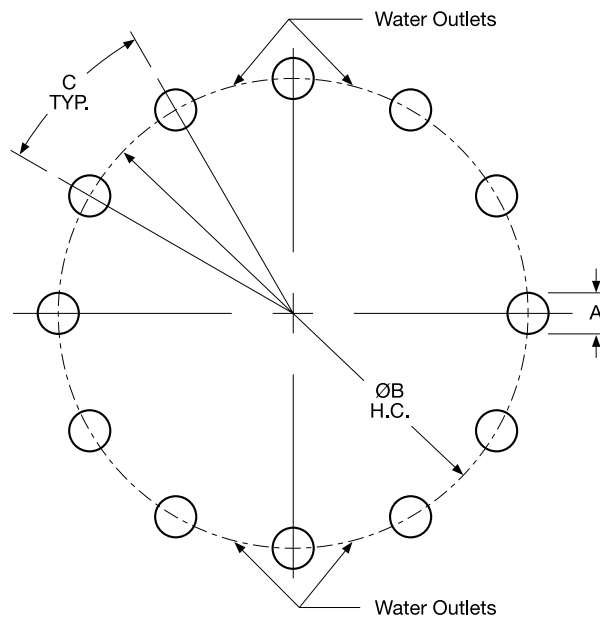

Sizes 19 & 25

Tension Brakes/High Heat Capacity

Kopper Kool Brakes Mounting Hole Pattern

Dimensions: inches (mm)

Model KKB	No. of Mounting Holes	A Size	B Hole Circle	No. of Holes, Hole Pattern is Based	C	D
6	4	0.34 (8.6)	8.000 (203.20)	4	45°	90°
8	4	17/32 (13.5)	11.125 (282.58)	6	60°	120°
11	4	21/32 (16.7)	14.75 (374.65)	6	60°	120°
14	6	21/32 (16.7)	17.500 (444.50)	8	45°	90°
16	10	21/32 (16.7)	20.000 (508.00)	12	30°	60°
18	10	21/32 (16.7)	22.000 (558.80)	12	30°	60°
19	12	11/16 (17.5)	22.000 (558.80)	12	30°	—
21	10	21/32 (16.7)	25.500 (647.70)	12	30°	60°
24H	10	21/32 (16.7)	28.750 (730.25)	12	30°	60°
25	12	21/32 (16.7)	28.750 (730.25)	12	30°	—
27	14	21/32 (16.7)	31.500 (800.10)	16	22.5°	45°
30	16	25/32 (19.8)	35.500 (901.70)	18	20°	40°
36H	16	13/16 (20.6)	42.000 (1,066.80)	18	20°	40°
436H	16	1.06 (26.9)	42.500 (1,079.50)	18	20°	40°
46	22	1.03 (26.2)	56.750 (1,441.45)	24	15°	30°

C

Tension Brakes/High Heat Capacity

Kopper Kool Brakes

Spring-Set Brakes

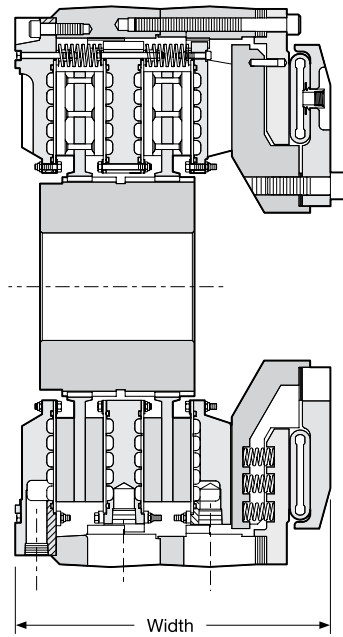

KKSS Brake

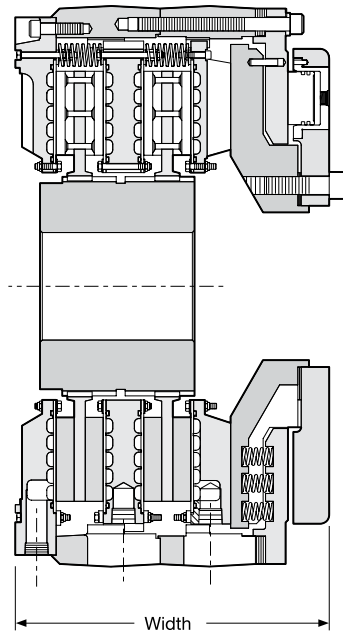

KKSS-HYD Brake

See previous pages for dimensional information.

Tension Brakes/High Heat Capacity

Kopper Kool Brakes Spring-Set Brakes

Dimensions: inches (mm)

Model Size ATD-	Assembly Number	Dynamic Torque Capacity*				Width	
		lb.in.	Nm	Release Pressure		in.	(mm)
				PSI	BAR		
KKSSB 218	7-318-210-113-0	48,000	5,434	90	6.2	15.00	(381)
KKSSB 224H	7-325-210-106-0 ³	104,800	11,840	75	5.2	17.59	(446.8)
KKSSB-HYD 124H	7-325-110-107-0	88,000	9,942	1,280	88.3	12.63	(320.8)
KKSSB-HYD 224H	7-325-210-107-0	160,000	18,077	1280	88.3	17.52	(445)
KKSSB 330H	7-331-310-300-0 ¹	748,900	84,612	100	6.9	22.69	(576.3)
KKSSB 236H ⁴	7-337-210-304-0 ²	649,400	73,370	120	8.3	22.03	(559.6)
KKSSB 336H ⁴	7-337-310-107-0 ^{1,2}	1,177,800	133,070	100	6.9	28.60	(726.4)
KKSSB 336H ⁴	7-337-310-106-0 ²	940,600	106,270	120	8.3	28.60	(726.4)

* Static torque will vary with temperature.

Note: Maximum water jacket inlet pressure is 60 PSI.

Brakes with as great as 50% higher torque capacity is available upon request.

¹ Current design is with enhanced linings. A unit with regular linings is available upon request.

² Current design is with the Marine Corrosion package. A Non-Marine unit is available upon request.

³ Current design is without hub. A unit with hub is available upon request.

⁴ Mounting same as 436H KK except with 42.500" (1,079.5 mm) hole circle.

Feature Differences: The KKSS brake uses air to release the brake, where as the KKSS-HYD brake uses hydraulic pressure to release the brake.

C

Tension Brakes/High Heat Capacity

Kopper Kool Custom Units

KKSS Clutch

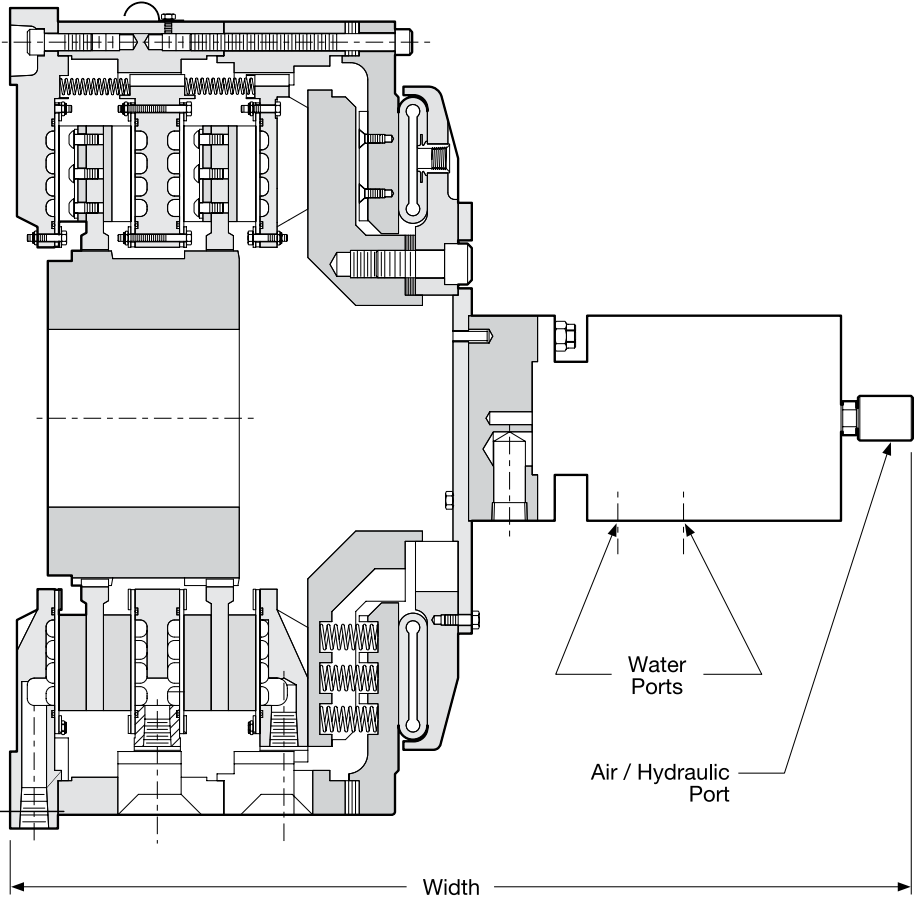

See previous pages for dimensional information.

Tension Brakes/High Heat Capacity

Kopper Kool Custom Units

KKSS Clutch

Dimensions: inches (mm)

Model Size ATD-	Assembly Number	Dynamic Torque Capacity* with Release Pressure		Heat Capacity HP (kW)	Roto - Coupling NPT	Max. Speed		Width in.(mm)
		lb.in.(Nm)	PSI (BAR)			R/C RPM	Unit RPM	
KKSSC 224	6-324-210-102-0 ²	74,250 (8,389)	75 (5.2)	347 ⁵ (260) ⁵	1-1/4"	40	475	33.00 (838.2)
KKSSC 324	6-324-310-102-0 ²	110,700 (12,507)	75 (5.2)	400 ⁶ (300) ⁶	1-1/4"	40	475	37.58 (954.5)
KKSSC 224H	6-325-210-100-0 ^{1,2}	157,225 (17,764)	75 (5.2)	566 ⁷ (425) ⁷	1-1/2"	250	475	38.87 (987.3)
KKSSC 324H	6-325-310-100-0 ^{1,2}	278,700 (31,488)	95 (6.6)	400 ⁷ (300) ⁷	1-1/4"	40	475	39.03 (991.4)
KKSSC 236H	TBD ^{2,3}	542,100 (61,247)	100 (6.9)	1,300 ⁶ (975) ⁶	2"	250	300	32.25 (819.2)
KKSSC-HYD 236H	6-337-210-100-0 ^{2,3}	542,100 (61,247)	1,450 (100.0)	1,300 ⁶ (975) ⁶	2"	250	300	32.25 (819.2)

* Static torque will vary with temperature.

Note: Maximum water jacket inlet pressure is 60 PSI.

Brakes with as great as 50% higher torque capacity is available upon request.

¹ Current design is with enhanced linings. A unit with regular linings is available upon request.

² Current design is with the Marine Corrosion package. A Non-Marine unit is available upon request.

³ Mounting same as 436H KK except with 42.500" (1,079.5 mm) hole circle.

⁵ Series hosing

⁶ Parallel hosing

⁷ Partial-parallel hosing

Feature Differences: The KKSS clutch uses air to release the clutch where as; the KKSS-HYD clutch uses hydraulic pressure to release the clutch.

C